

Space GPS Receiver – SGR-20

(Navigation and Timing)

Applications

- Navigation for LEO Missions
- Orbit and Position Determination
- Post-Manoeuvre Orbit Determination
- Payload Data Time Stamping
- Accurate Timing and Synchronisation
- Three Axis Attitude Determination

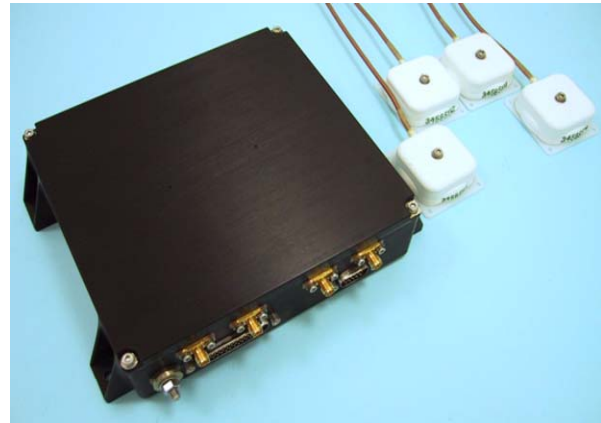

SGR-20 GPS Receiver and Antennas

Positioning and timing information provided by the receiver can be processed to obtain orbital information. SSTL can provide expertise on orbit determination solutions using the SSTL space GPS receiver

Features

- 24 Channel L1 C/A Code Space GPS Receiver
- Extensive Flight Heritage
- Manufactured to ECSS Standards
- Fast Start-up
- High Visibility and Redundancy
- Radiation Tolerant Design
- Four Active Patch Antennas Included
- 7 Year Design Life

Interfaces

- 50 Ohm antenna interfaces (SMA)
- CAN (ISO11898) and RS422 TM/TC Interface
- Pulse-Per-Second (IEE442) (TTL, RS422, LVDS)

Typical Performance

- Position to 10 m (95%)
- Velocity to 0.15 m/s (95%)
- Time to 500 ns
- Time To First Fix (cold) 200 – 350 s
- Time To First Fix (warm) 50 – 90 s
- 28 V unregulated supply, 5.5 W
- 195 x 162 x 48 mm, 0.95 kg

Options

- Low profile box configuration available
- Passive antenna and external LNA

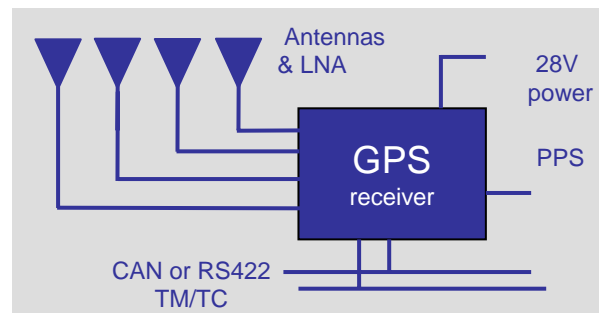

Typical SGR-20 Mission Deployment

Antenna Configurations:

- **Co-visible** – Antennas on space facing facet, 24 channels available for rapid acquisition. Attitude determination capability when suitably mounted.
- **Extra-visible** – Antennas on opposite facets of satellite, 12 channels allocated to each, permits parallel search and operation

Heritage

- 20 receiver units flown
- NASA, USAF and ESA Missions
- 65 orbit years operation

Other SSTL Navigation Products

- SGR-05U (1 Antenna, 12 Channels)
- SGR-07 (1 Antenna, 12 Channels)
- SGR-20 (4 Antennas, 24 Channels)
- SGR-GEO Receiver for GEO
- SGR Orbit Determination Solutions
- SGR Attitude Determination Solutions

Space GPS Receiver – SGR-20

(Navigation and Timing)

Radiation: Unit designed to be radiation tolerant with counter measures against SELs and a watchdog reset function

Antenna: Active patch antenna weighing 50g and having dimensions of 45x45x20mm

Non-Volatile Memory: Flash memory stored software to allow rapid booting and upgrades.

Performance

Based on circular polar low earth orbit with typical ionospheric and ephemeris error levels on signals and co-visible antenna configuration

Specifications

	Typical (95%)	Max (95%)
Orbital Position (3-D)	10m	20m
Orbital Velocity (3-D)	0.15m/s	0.25m/s
Time	0.5µs	1µs
Time to First Fix	Warm 50s Cold 200s	Warm 90s Cold 350s
Mass	950g	
Dimensions	195 x 162 x 48mm	
Power	5.5W at 28V (Supply 18-38V)	
Temperature	Operating -20°C to +50°C	
Random Vibration	15g _{rms} in all axis	
Radiation Tolerance	10kRad (Si)	

Typical Measurement Precision

Pseudo Range	0.9m
Carrier-Smoothed Range	0.15m
Carrier Phase Noise	2mm
Doppler Velocity	0.5m/s
Carrier Range Rate Velocity	0.03m/s

EMC: Tested as per MIL-STD-462D

Flight Software: Extensive flight heritage software used on many missions

User Interface: PC software provided for receiver monitoring, control and data processing

SSTL is ISO9001:2008 certified

Subsystems are manufactured to:

- ECSS Q-ST-70-08C
- ECSS Q-ST-70-38C

Standard delivery service includes:

- compliance testing
- vibration test
- thermal cycling
- user manual
- test results
- export license and shipping
- thermal vacuum testing available
- unit can be supplied prior to environmental testing

Surrey Satellite Technology Limited

SSTL has launched over 34 satellites gaining almost 200 years in-orbit experience. SSTL draws on its world-class expertise in both small satellite platform technology and high and medium resolution optical instruments. SSTL provides complete turn-key system solutions; spacecraft, ground station, launch, operations and image processing.

SSTL is unique in the space industry; able to design, manufacture and integrate multiple satellites in-house.

Changing the economics of space
www.sstl.co.uk