

Xenon Propulsion System

Applications

- Small Satellite Constellations
- Cost Effective Missions
- Orbit Circularisation and Control
- High Resolution Imaging Missions

Features

- Significantly safer handling compared with Hydrazine system
- Low cost propellant loading
- Employs a Resistojet Thruster to Maximise Specific Impulse
- No Sloshing or Disturbances from moving parts
- Xenon gas does not contaminate solar arrays, thermal control or instruments
- No Strict Thermal Controls Required

Key Specifications

- 20kg wet mass
- 15m/s for a 385kg spacecraft
- 120 bar Maximum operation pressure (x4 design margin on tank)

Interfaces

- CAN (ISO11898)

Options

- RS422 TM/TC interface
- Multiple thrusters
- Alternative tank configuration
 - Cylindrical or Spherical
- Propulsion system GSE
- Propellant Loading Services

Heritage

- Electronics on 5 DMC missions
- DMC+4 (2005)
- 5x RapidEye (2008)
- N2 (2009)
- Proba-2 (2009)



Xenon Hot Gas propulsion system

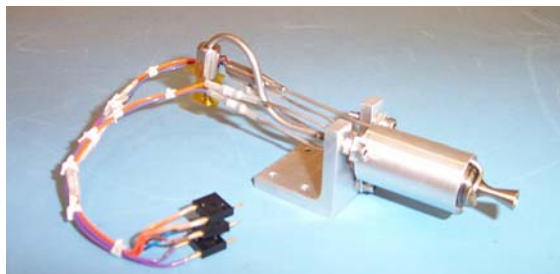

Resistojet Thruster

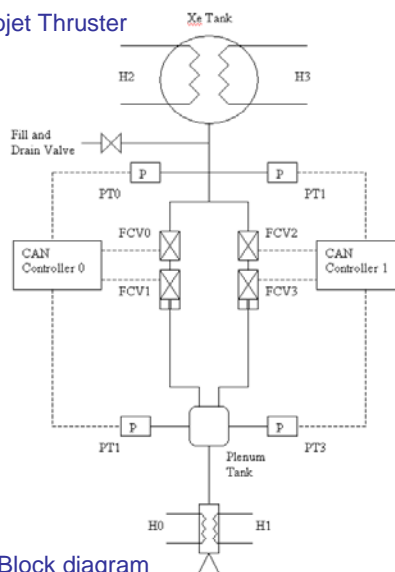

System Block diagram



Xenon Propulsion System

The Xenon propulsion system is designed for low cost, high performance missions requiring modest levels of in-plane orbit control.

The system employs a resistojet thruster, to achieve a superior volume Isp for a gas system

Through spacecraft pitch control, the single thruster can be used to implement any in-plane manoeuvre.

SSTL is ISO9000:2000 certified

- Manufacture and rework to
 - ECSS Q-70-80A
 - ESA PSS-01-738
 - ECSS Q-70-28A
 - Test to SSTL ISO9000:2000

Standard Delivery Service Includes

- Compliance Testing
- Vibration Test
- Thermal Cycling
- User manual
- Test Results
- Export License and Shipping

- Thermal Vacuum Testing available
- Unit can be supplied prior to environmental testing

Thrust	18mN
Resistojet power	2x 30W (prime and redundant)
Specific Impulse	48s nominal
Total impulse	5644Ns
Warm up	700s
Interfaces	28V power and CAN TM/TC
Mass	12kg Xenon 7.26kg dry mass
Dimensions	230x300x300mm
Operating Temperature	-20°C to 50°C
Random Vibration	12Grms (X-Y), 20Grms (Z)
Radiation	Compatible with 7.5 year mission in LEO

Surrey Satellite Technology Limited

SSTL has launched over 30 satellites gaining almost 200 years in-orbit experience. SSTL draws on its world-class expertise in both small satellite platform technology and high and medium resolution optical instruments. SSTL provides complete turn-key system solutions; spacecraft, ground station, launch, operations and image processing.

SSTL is unique in the space industry; able to design, manufacture and integrate multiple satellites in-house.

Changing the economics of space
www.sstl.co.uk

© Surrey Satellite Technology Ltd.

Tycho House, 20 Stephenson Road, Surrey Research Park, Guildford, Surrey, GU27YE, United Kingdom
Tel: +44(0)1483803803 | Fax: +44(0)1483803804 | Email: info@sstl.co.uk | Web: www.sstl.co.uk

